

VICTORY #7

INSIDER

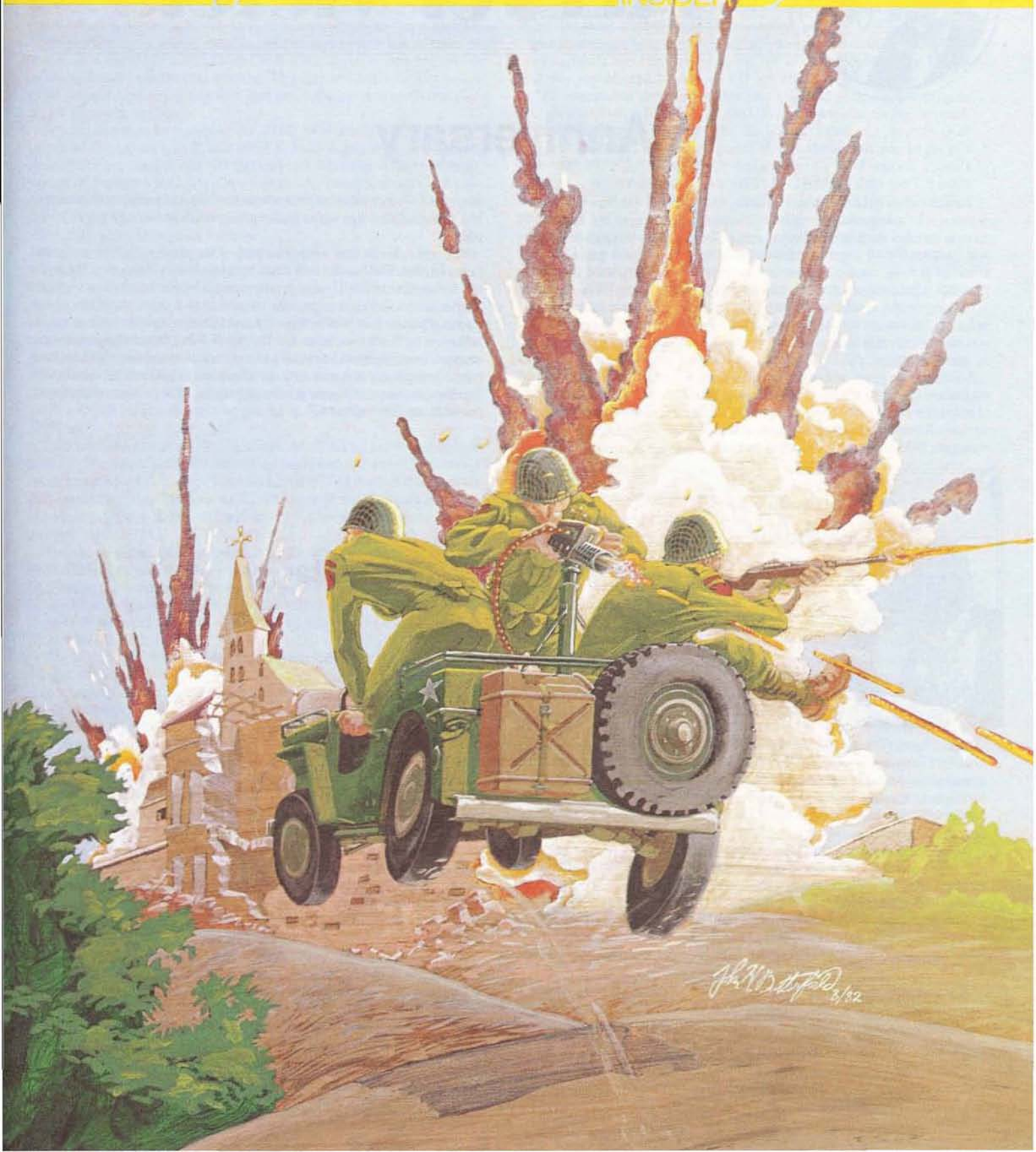

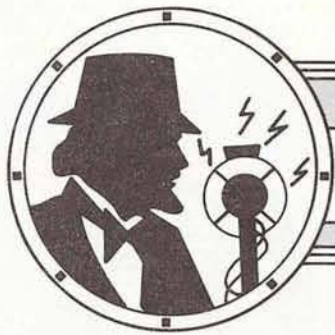

Thrilling TALES OF VICTORY

Anniversary

This is rather hard for me to believe, but with the 7th issue of *The Insider*, we have passed through our maiden year. I guess it's because putting together each issue takes up so little of my time. When wrestling with putting out 48 pages of *Heroes* and a dozen computer games, the effort of putting out 8-12 pages seems small by comparison. Look up from the grindstone and *poof*, there's six of these buggers on my desk.

Judging by the letters we've received, this publication is fulfilling a need, and for that, we thank you. There would not be *The Insider* if you weren't buying and playing the games. It's great to know we're in demand. Thank you.

For the next year, you can look forward to some changes in the magazine. The size of each issue is determined directly by the number of articles we have. There is no backlog of articles; everything that we accept will go into the next issue or the one after that. Not being a separate magazine helps us, since we can expand and contract according to our

needs. As we get more articles, the size of the magazine will increase. Not dramatically, but we're looking to publish at least 12 pages every issue.

We can only do that with your help. Our playtesters and designers help out, but *The Insider* is written by you. We're always on the lookout for new material. If what you have isn't long enough for an article, a letter will do. We are especially interested in articles about our newer games. Quite a few *Hell's Highway* and *Vietnam* articles have come in, followed by leader variants for *The Civil War* (but nothing about the strategic considerations, strangely enough). The Napoleonic gamers have been silent about *1809*, and only one short article has been received about *Panzer Command*. Perhaps you're still taking time to digest these tomes (munch, munch, munch).

— WEP



NATO Errata

009: (Note) Change the word "without" to "withhold."

053: The number indicated as the Movement Point Allowance is actually the Attack Strength, and the number indicated as the Attack Strength is actually the Movement Point Allowance.

056/057/058: References to the term "Paradrop" should read "Airborne Transport."

083: Note that some NATO formations (nationalities) have more than one HQ. Each HQ can support any and all combat units of its formation (nationality), regardless of nominal corps designation.

094: The reference to "supply range" should read "support range."

102: (Addition) Airborne, airmobile, and marine units transported to hexes from which they cannot trace supply are nonetheless automatically considered supplied during the first Joint Supply Determination

Phase following their transport.

113: The last sentence should read: "A unit moving by Strategic Road Movement can never enter an enemy Zone hex, an interdicted hex, or a hex outside a friendly country." (This correction also applies to 117.)

121: This rule should read as follows: "An eligible unit can use Air Transport to move to any land hex in enemy airspace except a rough or mountain hex."

123: This rule should read as follows: "An eligible unit can use Air Transport to move to any land hex in enemy airspace except a rough or mountain hex."

146: (Addition) Friendly reinforcements that are prevented from arriving by this rule are not permanently lost (except units used to meet

continued on page 14

The Victory Insider

Executive Editor: Mark Herman

Managing Editor: William E. Peschel

The Victory Games Staff: Mark Herman, Jerry Glichenhouse, Rosaria Baldari, Robert Kern, Gerry Klug, Susan Koch, Ted Koller, Michael E. Moore, Bob Ryer, Eric Lee Smith, Jim Talbot

Project Oversight: W. Bill

Contents Copyright © 1985 by Victory Games, Inc.

The Victory Insider is devoted to publishing articles about the products of Victory Games, Inc.

Send editorial and general mail to William E. Peschel, The Avalon Hill Game Company, 4517 Harford Rd., Baltimore, MD 21214. Subscriptions to *The General* are \$12.00 for one year, \$18.00 for two years. Address changes must be submitted at least 6 weeks in advance to guarantee proper delivery. Paid advertising is not accepted.

The Victory Insider is written largely by the gaming public. Articles should be typewritten, double-spaced, and written in English. Your address should be at the top of the title page. There is no limit to word length. Rejected articles will be returned if submitted with a stamped, self-addressed envelope.

Letters From The Outside

We welcome your comments on any subject. Send all Insider letters to Victory Insider, 4517 Harford Rd., Baltimore, MD 21214

Key Hexes In Highway

I read with interest Mr. Butterfield's article on *Hell's Highway* in the *Insider #2 (The General 21/1)*. I strongly disagree that, given effective British deployment, the Germans will be able to assault hex 7917 on turn 7 or 8. Given a decent drop, it is more likely to occur turn 16 or 17, if then. In order for the Allies to ensure such a happy state of affairs, it is important for the Red Devil commander to concentrate on grabbing key terrain (hexes) quickly. This article details the key hexes to be occupied on any given turn and notes the current problems that *Hell's Highway* suffers.

The key hexes to be occupied are 8018, 8414 and 8117 (this last requires an H unit) on turn 2, and 6918 as soon as possible. Occupation of the first three ensures that NO German unit will enter Arnhem without having to displace a Red Devil by combat. Occupation of hex 6918 surrounds the 9SS Recce unit (defending the bridge from hex 6818) to speed the breakthrough at Nijmegen. Everything a player does should be orchestrated with these goals in mind.

In order to ensure the above goals are met, let's review the key hexes to occupy at the end of movement of Turn One. Hex 7812 or 7813 must be occupied by an H unit in travel mode. A nonrecce unit in travel mode moves to 7611/7712. A Recce unit must be on the major road ready to go into travel mode. (Note that it is preferable to have both recce units so prepared and to have moved one recce unit to 7508 to check the 7408/7508 crossing. If the crossing does not blow, then putting an H unit into 7507 will ensure the recce unit crossing the Neder Rijn). The German unit in 8011 must either be attacked in great strength to ensure a D OR an H unit must be placed in 7911. One unit must move into 8210.

Turn two: the H unit in 7812/3 comes out of travel mode and moves to 8117. The Recce unit goes into travel mode and moves to 8018 (that's correct; *outside* of Arnhem). The unit in 7611/7712 stays in travel mode and moves to 7914. The unit in 8210 moves in travel mode to 8414. If you can throw a Recce unit across the Neder Rijn, do it. Move the artillery unit to 7812.

The above allows you the comfort of knowing no German unit will be in Arnhem on turn 2. Turn 3 can then be used to land reinforcements (if playing the hidden drop zone campaign scenario (21.2), we favor hex 7814 as the drop hex), move followup units to 8017 and 8115, and if the units are available, move two ground units to 7917 to assault hex 7816 with artillery support.

What's wrong with *Hell's Highway*? A bunch of irritating, albeit minor things:

1) In scenario 21.2, the Allies have perfect hindsight as to where to put their dropzones (e.g. as close as possible to Eindhoven). Correction: change rule 17.5 to say "not separated by a canal or river . . ."

2) In 21.2, the allies have perfect hindsight as to the entry location of certain early German reinforcements (most particularly the 106th Panzer Brigade), enabling them to prepare nasty receptions. Correction: for 21.2, the German player may bring on his reinforcements that start in tactical reserve boxes one turn early, but only in their connected operational reserve box and never before turn 2.

3) In all scenarios, the XXXth Corp seals off a number of entry areas on Map A by lining units adjacent to the entry area. Thus, the weakest Allied units may prevent entry of any number of German units. To add insult to injury, the Allies ensure maximum point scores by leaving multi-step units on roads, in travel mode, so that on the last turn of the game these units can all rush over the Waal. Correction: the allied player may not end a turn with a unit adjacent to an entry area hex.

Given a decent Red Devil drop, that is, two H and one other infantry unit landing undisrupted, plus one Recce unit landing in any state, then the Germans must pray for a real Allied disaster elsewhere in order to have a shot at winning this game. Players should consider how radically the game balance changes with all other elements the same but not allowing a British Recce unit to enter hex B8018 on turn 2.

Vietnam Counterplay

The second *Vietnam* feature (*Insider #5, General 21/4*) was something of a letdown after the first installment. Although Tony Curtis apparently based his articles on a playtest prototype, I suspect sloppy editing is behind most of the errors in the second piece.

For instance, in the diagrams for the first sample operation, the ARVN 16/9 regiment was represented by the ARVN 15/9 counter. The US 9th HQ was represented by the ARVN 9th HQ in 4 places.

The operational description was also slipshod. The US 2/9 brigade HQ should travel to hex 1774 by road, saving a precious airmobile point. It should not pursue. In the pursuit, the US 3/2/9 battalion (airmobilized) actually needs 5.5 movement points to exit the interdicted target hex and reach 1978 (it has only 5). It should move to 1878 instead. There's no point in airmobilizing the ARVN 16/9 regiment, since the US 1/2/9 can easily cover the VC's northern escape route. The US 2/2/9 battalion attacks the VC at 3-to-1, giving a +3 modifier with terrain and pursuit (the US commits only 2.5 ground points to the attack, taking its losses on the "1 to 3.5" column). If the operation ends here, only 3 airmobile points are used, not 7.

Errors in the other operations were similar, e.g. a pursuing unit ignoring target hex interdiction in the fourth example.

Mistakes aside, the article raised some interesting points. In particular, the fourth example implied that the same airmobile point could be switched among different units in one operation. The rules aren't explicit on this point, but if riverine assignments last for the duration of an operation (rule 8.3), then I think airmobile assignments should, too.

Mr. Curtis advised the US player to keep ARVN units out of target hexes, to avoid lowering the pursuit bonus if the VC remain for later rounds. I have to disagree. In the vast majority of cases, the US player would be overjoyed for the VC to stay put for even one round of combat, let alone two. In round one, all operating ground units can attack, raising the odds. Round two is even better, as US artillery shifts from interdiction to fire support. Try playing the article's first search & destroy example with a Ranger in the target hex, and see if the VC gain anything by holding their ground.

Mr. Curtis favors extensive use of airpower in both articles. My own preference is for artillery, which is much cheaper (e.g. 7 points of 155mm artillery for the price of 3 air points). True, air points have no range limit, but for the same commitment, the US player can buy enough artillery and airmobile points to provide adequate coverage. Furthermore, a used air point is gone for the rest of the turn. A used artillery unit can still fire defensively in later US or NLF operations.

Airpower does have one major advantage: it's the only way the US player can destroy NLF commitment at its source in North Vietnam. Even so, I think the commitment required for a major bombing campaign is worth more when taken instead as artillery and airmobile points. The increase in VC casualties pays off in US morale points (for "body count"), faster pacification (more morale points), and NLF commitment expended on VC recruits. When the NVA takes over "depacification" from the VC, artillery is more cost-effective than airpower in dealing with it.

Despite the minor mistakes in the second installment, both *Vietnam* articles make excellent additions to an excellent game. *Victory Insider* already a cut above *The General* in quality, will be even better when the editing is improved. I'm looking forward to upcoming issues.

Gary Hladik
Saratoga, CA

Hmmm, I'm not sure if criticizing the editing is a good way to get a letter published, since I'm the one responsible for the diagram errors. But Mr. Hladik is right, for reasons too mundane to get into here. As for the thoughts contained in the article, it will be up to Mr. Curtis to decide if he wants to respond. Tony?—WEP

An Ambush! Special Scenario

By Paul L. Fasoldt

Mission VI1: Traffic Control

September 1944. Your squad has been scouting ahead of the division in an attempt to locate German Reinforcements reported to be gathering for a counterattack. Your squad has reached a small village at a vital crossroads. Headquarters has ordered you to stay put and report any enemy movement in the area.

YOUR SQUAD

You can use the pre-generated squad, your own continuing squad, or you can generate a new one. Buy new equipment for your squad, but since you have been travelling fast and light, you cannot buy MMGs. Due to recent rains causing poor road conditions, intelligence reports no tanks are expected. In addition, you receive at no cost one flamethrower, two satchel charges, and a radio. Use a spare blank marker or a piece of file card to represent the flamethrower.

SET UP

Use map B. The top of the map is the north edge. For each of the following hexes in order, roll one die. On an even number, place a rubble marker. On an odd result, go to the next hex. Stop when you have made it through the list, or after three markers have been placed. The hexes: L5, P5, Q8, Q10, M10, M6, Q5, R7, P9, N9.

Set your squad up in at least three buildings, not more than five hexes from N7 (include N7 when counting distance).

The water barrier is a river and can only be crossed at an intact bridge.

Several vehicles in this scenario do not appear in *Ambush!*. If you have the *Purple Heart* module, use the appropriate counters from it. If not, use pieces of file card with the vehicle name on one side and the vehicle name with destroyed on the other side.

After your squad is set up, conduct Paragraph Checks and then see 101.

VICTORY

Victory Point accumulation and loss will be revealed during the mission. VP loss for killed/incapacitated men and means for ending the mission will also be revealed during the course of the mission.

VI1. Flamethrowers

Flamethrowers cost 10 points and have a break percentage of 05. They have a 35% chance of running out of fuel, require one portage box to carry, and cannot be snaffired. When in the same hex as the target, they need an 8 to hit; in an adjacent hex, a 6 is needed, and at 2-3 hex range, a 5. There is no fire combat modifier to hit a hex; range is the only consideration. When attacking soldiers, vehicles or structures, see below for modifiers.

If a soldier carrying a flamethrower is fired on, and hit with a result of other than panic, roll PC dice. If 10 or less, the flamethrower explodes: the carrying soldier is killed, the hex burns, and all other occupants of the hex roll on the Pistol row of the Damage Table. If the soldier carrying the flamethrower is fired upon and a miss or panic results, roll PC dice. On a result of 01 or less, damage occurs as above.

An incapacitated soldier in a hex set afire is killed. Any equipment represented by its own marker (MG, bazooka, satchel charge, radio, flamethrower) in a hex that is set afire must be exited next turn, or it is destroyed and removed from the map.

Personal weapons abandoned in a building hex is destroyed and must be marked off on your squad record.

Fire combat conducted through a burning hex has a -1 modifier for each burning hex it passes through, including the target hex.

Damage Effects

All targets. Any hit causes the hex to burn as well as any non-soldier target. (Exception: ford, stream and river hexes). If attacking a target, and the result is a miss, roll one die: odd—no effect; even—hex burns.

Soldiers and vehicles in a hex which is set afire must exit the next turn. If no movement reference is given, roll one die:

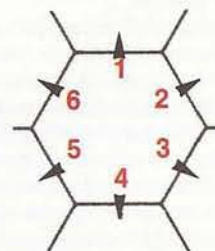

7-0: Roll Again

Soldiers and vehicles directed to enter a burning hex will remain where they are. Soldiers and occupants of non-crew vehicles will conduct 802. Tank, Jagdpanther, and armored car will conduct best fire with machinegun at closest target.

Building, vehicle, woods, wooden bridge, brush. Burns until the end of the mission.

Road, open, cover, stone bridge, rough, crater. Burns until the end of the current round.

Ford, stream, river. No effect.

Bunker. Use -3 fire combat modifier unless in the same hex when attempting to hit an aperture. A hit result destroys the bunker and kills all occupants. If attempting to hit a wall, use +4 fire combat modifier. A hit result causes occupants to lose one turn (if any remaining in the current round.)

Tank, Jagdpanther, armored car, halftrack. If open, use -3 fire combat modifier unless in same hex. A hit result destroys vehicle and kills all occupants. If closed, use vehicle size modifier for location of vehicle. A hit causes vehicle to lose one turn if any remaining in that round.

All other vehicles. Use vehicle size modifier for location of vehicle. A hit disables vehicle and each occupant rolls for damage on the semi-automatic rifle row of the Damage Table.

Soldier. Use fire combat modifier for current stance and location. There is a +1 modifier for each additional soldier in the hex. Hit is resolved on HMG row of Damage Table.

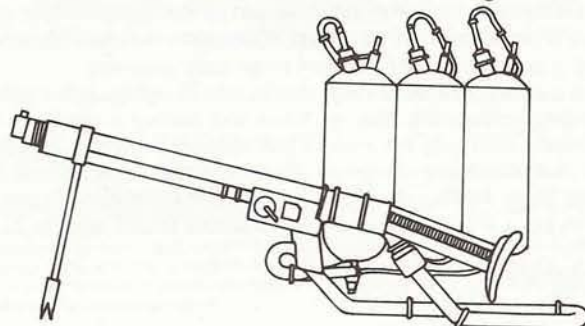

<p>US 08/J Soldier</p> <p>IN: 3 PC: 5 WS: +1 MPA: 4</p> <p>Semi-Automatic Rifle</p> <p>3 SAR Clips; 2 Grenades</p> <p>NOTES: J and K must stay within sight of each other until fired upon or in hex with commander.</p>	<p>US 09/K Soldier</p> <p>IN: 2 PC: 2 WS: -1 MPA: 4</p> <p>Semi-Automatic Rifle; Bazooka</p> <p>3 SAR Clips; 3 Bazooka Charges</p> <p>NOTES: Bazooka not prepared on entry. J and K must stay within sight of each other until fired upon or in hex with commander.</p>
---	--

<p>GE 11/L and M Motorcycle with Sidecar +2 VP</p> <p>Driver (L): IN: 3 PC: 5 WS: 0 DS: 6 MPA: 4 Gunner (M): IN: 3 PC: 6 WS: +2 DS: 2 MPA: 4 Soldier L has Machine Pistol; Grenade; +1 VP Soldier M has LMG; Pistol; 2 Grenades; +1 VP</p> <table border="1" style="width: 100%; border-collapse: collapse;"> <thead> <tr> <th rowspan="2">DIE</th> <th colspan="2">CONDITION</th> <th colspan="2">SPECIAL</th> </tr> <tr> <th>1-4</th> <th></th> <th>X</th> <th>S</th> </tr> </thead> <tbody> <tr> <td>0-2</td> <td>190</td> <td></td> <td>815</td> <td>833</td> </tr> <tr> <td>3</td> <td>190</td> <td></td> <td>170</td> <td>800</td> </tr> <tr> <td>4-7</td> <td>190</td> <td></td> <td>868</td> <td>869</td> </tr> <tr> <td>8-9</td> <td>190</td> <td></td> <td>862</td> <td>178</td> </tr> </tbody> </table> <p>NOTES: Self-preservation does NOT apply if motorcycle still active. LMG may not fire in rear facing while gunner is in sidecar. If motorcycle is disabled/immobilized, put special reaction X into effect for survivors. If driver is incapacitated or killed, gunner spends one turn to become driver.</p>	DIE	CONDITION		SPECIAL		1-4		X	S	0-2	190		815	833	3	190		170	800	4-7	190		868	869	8-9	190		862	178	<p>GE 12 Staff Car +2 VP</p> <p>Driver (P): IN: 1 PC: 3 WS: +1 DS: 8 MPA: 3 Officer (N): IN: 4 PC: 3 WS: +1 DS: 4 MPA: 4 Soldier P has Machine Pistol; Grenade; +1 VP Soldier N has Pistol; +2 VP</p> <p>NOTES: If officer is captured, gain 2 VPs. Actions for this group depends upon who is inactive. If none or officer inactive: 191; if driver inactive, officer spends one turn to become driver and then conducts 191. If staff car is inactive, the driver conducts 865 and the officer 822. The driver cannot panic while in an active staff car.</p>
DIE		CONDITION		SPECIAL																										
	1-4		X	S																										
0-2	190		815	833																										
3	190		170	800																										
4-7	190		868	869																										
8-9	190		862	178																										

<p>GE 13 Truck 1 Truck +2 VP</p> <p>Driver (R): IN: 2 PC: 4 WS: +1 DS: 4 MPA: 4 Assistant (Q): IN: 1 PC: 1 WS: 0 DS: 0 MPA: 3 Soldier R has Bolt Rifle; Grenade; +1 VP Soldier Q has Bolt Rifle; Grenade; +1 VP</p> <table border="1" style="width: 100%; border-collapse: collapse;"> <thead> <tr> <th rowspan="2">DIE</th> <th colspan="2">CONDITION</th> <th colspan="2">SPECIAL</th> </tr> <tr> <th>1-4</th> <th></th> <th>Y</th> <th>S</th> </tr> </thead> <tbody> <tr> <td>0-1</td> <td>191</td> <td></td> <td>801</td> <td>839</td> </tr> <tr> <td>2-4</td> <td>191</td> <td></td> <td>802</td> <td>802</td> </tr> <tr> <td>5</td> <td>191</td> <td></td> <td>862</td> <td>819</td> </tr> <tr> <td>6-9</td> <td>191</td> <td></td> <td>868</td> <td>971</td> </tr> </tbody> </table> <p>NOTES: Self-preservation does NOT apply while in active truck. If truck disabled/immobilized, put special reaction Y into effect for survivors. If driver is killed or incapacitated, assistant spends one turn to become driver. Driver or assistant cannot panic while in active vehicle.</p>	DIE	CONDITION		SPECIAL		1-4		Y	S	0-1	191		801	839	2-4	191		802	802	5	191		862	819	6-9	191		868	971	<p>GE 16 Halftrack +2 VP</p> <p>Driver (W): IN: 1 PC: 0 WS: -1 DS: 2 MPA: 3 Assistant (T): IN: 2 PC: 2 WS: +1 DS: 0 MPA: 4 Soldier W has Bolt Rifle; Grenade; +1 VP Soldier T has Machine Pistol; 2 Grenades; +1 VP</p> <table border="1" style="width: 100%; border-collapse: collapse;"> <thead> <tr> <th rowspan="2">DIE</th> <th rowspan="2">CONDITION</th> <th colspan="2">SPECIAL</th> </tr> <tr> <th>A</th> <th>S</th> </tr> </thead> <tbody> <tr> <td>0</td> <td>195</td> <td>868</td> <td>869</td> </tr> <tr> <td>1-3</td> <td>195</td> <td>864</td> <td>178</td> </tr> <tr> <td>4-7</td> <td>195</td> <td>869</td> <td>839</td> </tr> <tr> <td>8-9</td> <td>195</td> <td>865</td> <td>833</td> </tr> </tbody> </table> <p>NOTES: If halftrack is disabled/immobilized, put special reaction A into effect for survivors and see 154. If driver is killed or incapacitated, assistant spends one turn to become driver. Driver or assistant cannot panic while in active vehicle. Before putting this vehicle into play, see 155.</p>	DIE	CONDITION	SPECIAL		A	S	0	195	868	869	1-3	195	864	178	4-7	195	869	839	8-9	195	865	833
DIE		CONDITION		SPECIAL																																																
	1-4		Y	S																																																
0-1	191		801	839																																																
2-4	191		802	802																																																
5	191		862	819																																																
6-9	191		868	971																																																
DIE	CONDITION	SPECIAL																																																		
		A	S																																																	
0	195	868	869																																																	
1-3	195	864	178																																																	
4-7	195	869	839																																																	
8-9	195	865	833																																																	

<p>GE 14 Truck 2 Truck +2 VP</p> <p>Driver (V): IN: 1 PC: 3 WS: +1 DS: 2 MPA: 3 Assistant (S): IN: 2 PC: 3 WS: +1 DS: 2 MPA: 4 Soldier V has Bolt Rifle; Grenade; +1 VP Soldier S has Bolt Rifle; Grenade; +1 VP</p> <table border="1" style="width: 100%; border-collapse: collapse;"> <thead> <tr> <th rowspan="2">DIE</th> <th colspan="2">CONDITION</th> <th colspan="2">SPECIAL</th> </tr> <tr> <th>1-4</th> <th></th> <th>Y</th> <th>S</th> </tr> </thead> <tbody> <tr> <td>0-3</td> <td>191</td> <td></td> <td>868</td> <td>971</td> </tr> <tr> <td>4-6</td> <td>191</td> <td></td> <td>801</td> <td>819</td> </tr> <tr> <td>7-8</td> <td>191</td> <td></td> <td>862</td> <td>839</td> </tr> <tr> <td>9</td> <td>191</td> <td></td> <td>809</td> <td>802</td> </tr> </tbody> </table> <p>NOTES: Self-preservation does NOT apply while in active truck. If truck disabled/immobilized, put special reaction Y into effect for survivors. If driver is killed or incapacitated, assistant spends one turn to become driver. Driver or assistant cannot panic while in active vehicle.</p>	DIE	CONDITION		SPECIAL		1-4		Y	S	0-3	191		868	971	4-6	191		801	819	7-8	191		862	839	9	191		809	802	<p>GE 15/Y Armored Car +3 VP (+2 VP if knocked out)</p> <table border="1" style="width: 100%; border-collapse: collapse;"> <thead> <tr> <th rowspan="2">Act Crew</th> <th colspan="8">ACTION DIE</th> </tr> <tr> <th>IN</th> <th>PC</th> <th>WS</th> <th>DS</th> <th>0-3</th> <th>4-5</th> <th>6-8</th> <th>9</th> </tr> </thead> <tbody> <tr> <td>3</td> <td>5</td> <td>8</td> <td>+2</td> <td>6</td> <td>192</td> <td>194</td> <td>193</td> <td>196</td> </tr> <tr> <td>2</td> <td>3</td> <td>4</td> <td>+1</td> <td>5</td> <td>193</td> <td>196</td> <td>194</td> <td>196</td> </tr> <tr> <td>1</td> <td>1</td> <td>1</td> <td>-1</td> <td>2</td> <td>196</td> <td>196</td> <td>196</td> <td>196</td> </tr> </tbody> </table> <p>NOTES: If armored car is disabled or immobilized and s7 has not occurred, see 111.</p>	Act Crew	ACTION DIE								IN	PC	WS	DS	0-3	4-5	6-8	9	3	5	8	+2	6	192	194	193	196	2	3	4	+1	5	193	196	194	196	1	1	1	-1	2	196	196	196	196
DIE		CONDITION		SPECIAL																																																																						
	1-4		Y	S																																																																						
0-3	191		868	971																																																																						
4-6	191		801	819																																																																						
7-8	191		862	839																																																																						
9	191		809	802																																																																						
Act Crew	ACTION DIE																																																																									
	IN	PC	WS	DS	0-3	4-5	6-8	9																																																																		
3	5	8	+2	6	192	194	193	196																																																																		
2	3	4	+1	5	193	196	194	196																																																																		
1	1	1	-1	2	196	196	196	196																																																																		

GE 17/X **NCO**
+2 VP (+2 VP if captured)

IN: 4 PC: 7 WS: 0 DS: 6 MPA: 4

Machine Pistol; Luger; 2 Grenades

DIE	CONDITION		SPECIAL	
	4		S	
0	866		812	
1-3	864		802	
4-7	832		833	
8-9	865		178	

GE 18/U **Infantry**
+1 VP

IN: 3 PC: 5 WS: 0 DS: 4 MPA: 4

Machine Pistol; 2 Grenades

DIE	CONDITION		SPECIAL	
	4		S	
0	865		178	
1-4	869		833	
5-7	866		802	
8-9	864		812	

GE 19 **Infantry**
+1 VP

Machine Pistol; 2 Grenades

DIE	CONDITION		SPECIAL	
	4		S	
0-3	869		833	
4-6	864		812	
7	866		833	
8-9	865		178	

NOTES: Pick one German at random from those killed or incapacitated. Using his IN, roll for other characteristics as if generating a new American (see Squad Generation, page 9 of the AMBUSH! rules, sections 5 through 8.) If no German has been killed or incapacitated, GE 19 is not activated. You still get +1 VP; you'll need it.

VEHICLE SUMMARY

ARMORED CAR WITH LIGHT MACHINEGUN

Small Vehicle; Armored; Open Only

CREW: 3

SLOW MOVEMENT POINT ALLOWANCE: 4

FAST MOVEMENT POINT ALLOWANCE: 8

Hit Chart

ITEM HIT	FACING HIT		
	Front	Side	Rear
Wheel	0	0-2	0
Body	1-4	3-5	1-4
Turret	5-6	6-7	5-7
Crew	7-9	8-9	8-9

Damage Effects

Wheel. If wheel is hit and penetration result is light, armored car cannot be driven fast; make an immediate Accident Check. If penetration result is medium or heavy, an accident occurs; make an immediate Accident Check. **Body.** If body is hit and penetration result is light, roll on the Pistol row of the Damage Table. If result is incapacitated or killed, reduce the crew by one; otherwise, no effect. If penetration result is medium, roll on the semi-automatic rifle row of the Damage Table and follow the same procedure as above. If the penetration result is heavy, the car is destroyed and the crew is killed. **Turret.** If the result is light, LMG cannot fire for the rest of the current round. If the result is medium or heavy, the turret is destroyed; reduce the crew by one and the armored car cannot fire for the rest of the mission. **Crew.** Reduce the crew by one. Considered a tank for grenade/satchel charge attacks and on the Accident Table.

HALFTRACK

Large Vehicle; Armored; Open Only

MAXIMUM OCCUPANTS: 8

SLOW MOVEMENT POINT ALLOWANCE: 4

FAST MOVEMENT POINT ALLOWANCE: 7

Hit Chart

ITEM HIT	FACING HIT		
	Front	Side	Rear
Driver	0-1	0-1	—
Assistant	2-3	2-3	—
Tire	4-5	4	—
Tread	6	5-6	0-1
Body	7-9	7-9	2-9

Damage Effects

Driver. Roll for damage using the Damage Table of the attacking weapon. If driver panics or is wounded, make an immediate Accident Check. If killed or incapacitated, an accident occurs, roll on the Accident Table. **Assistant.** Roll for damage using the Damage Table of the attacking weapon. **Tire.** Vehicle cannot be driven fast. If occupied, make an immediate Accident Check. **Tread.** If result is a penetration, the halftrack is immobilized and cannot move again. **Body.** If the penetration result is light, one passenger is killed. If the result is medium or heavy, the halftrack is destroyed and all occupants are killed. Considered a tank for grenade/satchel charge attacks and on the Accident Table.

MOTORCYCLE WITH SIDECAR

Small Vehicle; Non-Armored; Open Only

MAXIMUM OCCUPANTS: 3

SLOW MOVEMENT POINT ALLOWANCE: 6

FAST MOVEMENT POINT ALLOWANCE: 12

Hit Chart

ITEM HIT	NUMBER OF OCCUPANTS			
	0	1	2	3
Tire	0-3	0-3	0-3	0-2
Body	4-9	4-8	4-7	3-6
Driver	—	9	8	7
Sidecar Passenger	—	—	9	8
Pillion Rider	—	—	—	9

Damage Effects

Tire. Vehicle cannot be driven fast. If occupied, make an immediate Accident Check. **Body.** Resolve combat using Damage Table for attacking weapon. If result is a penetration result, the motorcycle is disabled. If not a penetration result, make an immediate Accident Check. **Driver.** Roll for damage using the Damage Table of the attacking weapon. If driver panics or is wounded, make an immediate Accident Check. If driver is incapacitated or killed, an accident occurs; roll on the Accident Table. **Sidecar Passenger or Pillion Rider.** Roll on the Damage Table for the attacking weapon. Considered a car for grenade/satchel charge attacks and on the Accident Table.

TRUCK

Large Vehicle; Non-Armored; Open Only

MAXIMUM OCCUPANTS: 10

SLOW MOVEMENT POINT ALLOWANCE: 4

FAST MOVEMENT POINT ALLOWANCE: 8

Hit Chart

ITEM HIT	NUMBER OF OCCUPANTS				
	0	1	2	3	4+
Tire	0-1	0-1	0	0	0
Body	2-9	2-7	1-5	1-4	1-3
Driver	—	8-9	6-7	5-6	4-5
Assistant	—	—	8-9	7-8	6-7
Passenger	—	—	—	9	8-9

Damage Effects

Tire. Vehicle cannot be driven fast. If occupied, make an immediate Accident Check. **Body.** Resolve combat using Damage Table for the attacking weapon. If result is a light penetration result, reduce passengers (if any) by one. If penetration result is medium or heavy, truck is destroyed. **Driver.** Roll for damage using the Damage Table of the attacking weapon. If driver panics or is wounded, make an immediate Accident Check. If driver is incapacitated or killed, an accident occurs; roll on the Accident Table. **Assistant.** Roll on the Damage Table for the attacking weapon. **Passenger.** Reduce the number of passengers by one. Considered a car for grenade/satchel charge attacks and on the Accident Table.

	A	B	C	D	E	F	G	H	I	J	K	L	M	N	O	P	Q	R	S	T	U	V	W	X	Y	RE
	NONE	NONE	NONE	NONE	NONE	NONE	NONE	NONE	NONE	NONE	NONE	NONE	NONE	NONE	NONE	NONE	NONE	NONE	NONE	NONE	NONE	NONE	NONE	NONE	NONE	NONE
\$5 106	NONE	NONE	NONE	NONE	NONE	NONE	NONE	NONE	NONE	NONE	NONE	NONE	NONE	NONE	NONE	NONE	NONE	NONE	NONE	NONE	NONE	NONE	NONE	NONE	NONE	NONE
xxx	NONE	NONE	NONE	xxx	xxx	NONE	H-6	I-7	NONE	K-6	L-6	M-7	NONE	NONE	NONE	O-7	P-6	NONE	NONE	NONE	T-5	U-6	NONE	NONE	NONE	
NONE	NONE	NONE	NONE	NONE	xxx	xxx	xxx	NONE	NONE	K-9	L-8	M-9	M-8	NONE	NONE	NONE	P-8	O-9	NONE	NONE	NONE	NONE	NONE	\$5 106	\$5 106	
\$5 106	NONE	NONE	NONE	NONE	NONE	NONE	xxx	I-12	I-11	J-11	NONE	NONE	NONE	NONE	NONE	NONE	NONE	R-11	NONE	NONE	NONE	NONE	NONE	\$5 106	\$5 106	
NONE	NONE	NONE	NONE	NONE	NONE	NONE	NONE	NONE	NONE	NONE	NONE	NONE	NONE	NONE	NONE	NONE	NONE	xxx	NONE	NONE	NONE	NONE	NONE	NONE	NONE	
\$5 106	NONE	NONE	NONE	NONE	NONE	NONE	NONE	NONE	NONE	NONE	NONE	NONE	NONE	NONE	NONE	NONE	NONE	NONE	NONE	NONE	NONE	NONE	NONE	NONE	NONE	
\$5 106	NONE	\$5 106	\$5 106	\$5 106	\$5 106	NONE	NONE	NONE	NONE	NONE	NONE	NONE	NONE	NONE	NONE	NONE	NONE	NONE	NONE	NONE	xxx	NONE	NONE	\$5 106	\$5 106	
\$5 106	NONE	NONE	NONE	NONE	NONE	NONE	NONE	NONE	NONE	NONE	NONE	NONE	NONE	NONE	NONE	NONE	NONE	NONE	NONE	NONE	NONE	NONE	NONE	NONE	NONE	
NONE	NONE	NONE	NONE	xxx	xxx	NONE	J-9	L-9	NONE	NONE	NONE	NONE	NONE	\$1 102	NONE	NONE	NONE	R-9	NONE	NONE	NONE	NONE	NONE	\$5 106	\$5 106	
\$5 106	NONE	NONE	NONE	NONE	NONE	NONE	NONE	NONE	NONE	NONE	NONE	NONE	NONE	NONE	NONE	NONE	NONE	NONE	NONE	NONE	NONE	NONE	NONE	NONE	NONE	
NONE	NONE	NONE	NONE	NONE	NONE	NONE	972	H-12	I-13	J-12	NONE	NONE	NONE	NONE	NONE	NONE	NONE	R-12	107	NONE	NONE	NONE	NONE	\$5 106	\$5 106	
NONE	NONE	NONE	NONE	NONE	NONE	NONE	xxx	xxx	xxx	xxx	NONE	xxx	NONE	xxx	xxx	xxx	NONE	xxx	xxx	NONE	NONE	NONE	xxx	NONE	NONE	
NONE	NONE	NONE	NONE	NONE	NONE	NONE	xxx	xxx	xxx	xxx	NONE	xxx	NONE	xxx	xxx	xxx	NONE	NONE	NONE	NONE	T-15	U-16	V-16	NONE	NONE	
NONE	xxx	xxx	xxx	NONE	NONE	NONE	NONE	NONE	NONE	NONE	NONE	NONE	NONE	\$1 102	NONE	NONE	NONE	O-6	NONE	NONE	NONE	NONE	NONE	NONE	NONE	
NONE	NONE	NONE	NONE	NONE	NONE	NONE	xxx	xxx	NONE	NONE	NONE	NONE	NONE	NONE	NONE	NONE	NONE	R-5	S-5	T-4	NONE	NONE	NONE	NONE	NONE	
NONE	NONE	NONE	NONE	NONE	NONE	NONE	xxx	NONE	NONE	NONE	NONE	NONE	NONE	NONE	NONE	NONE	NONE	NONE	NONE	NONE	NONE	NONE	\$5 106	\$5 106	\$5 106	
NONE	NONE	NONE	NONE	NONE	NONE	NONE	xxx	NONE	NONE	NONE	NONE	NONE	NONE	NONE	NONE	NONE	NONE	R-10	NONE	NONE	NONE	NONE	NONE	\$5 106	\$5 106	
\$5 106	NONE	NONE	NONE	NONE	NONE	NONE	xxx	NONE	NONE	NONE	NONE	NONE	NONE	NONE	NONE	NONE	NONE	R-13	NONE	NONE	NONE	NONE	NONE	\$5 106	\$5 106	
NONE	NONE	NONE	NONE	NONE	NONE	NONE	NONE	NONE	NONE	NONE	NONE	NONE	NONE	NONE	NONE	NONE	NONE	NONE	NONE	NONE	NONE	NONE	NONE	NONE	NONE	
NONE	xxx	xxx	xxx	NONE	NONE	NONE	NONE	NONE	NONE	NONE	NONE	NONE	NONE	\$1 102	NONE	NONE	NONE	O-8	NONE	NONE	NONE	NONE	NONE	NONE	NONE	
NONE	NONE	NONE	NONE	NONE	NONE	NONE	NONE	NONE	NONE	NONE	NONE	NONE	NONE	NONE	NONE	NONE	NONE	NONE	NONE	NONE	NONE	NONE	NONE	NONE	NONE	
NONE	NONE	NONE	NONE	NONE	NONE	NONE	NONE	NONE	NONE	NONE	NONE	NONE	NONE	NONE	NONE	NONE	NONE	NONE	NONE	NONE	NONE	NONE	NONE	NONE	NONE	
NONE	NONE	NONE	NONE	NONE	NONE	NONE	NONE	NONE	NONE	NONE	NONE	NONE	NONE	NONE	NONE	NONE	NONE	NONE	NONE	NONE	NONE	NONE	NONE	NONE	NONE	
NONE	NONE	NONE	NONE	NONE	NONE	NONE	NONE	NONE	NONE	NONE	xxx	NONE	NONE	NONE	NONE	NONE	NONE	NONE	NONE	NONE	NONE	NONE	xxx	xxx	xxx	
NONE	NONE	NONE	NONE	NONE	NONE	NONE	NONE	NONE	NONE	NONE	xxx	NONE	NONE	NONE	NONE	NONE	NONE	NONE	NONE	NONE	NONE	NONE	xxx	xxx	xxx	
NONE	NONE	NONE	NONE	NONE	NONE	NONE	NONE	NONE	NONE	NONE	NONE	NONE	NONE	NONE	NONE	NONE	NONE	NONE	NONE	NONE	NONE	NONE	NONE	NONE	122	

VICTORY INSIDER Mission 1: Traffic Control Condition 1

Paragraphs

100. Roll one die to determine the next hex entered:

0-1: O7

2-3: O8

4-6: M8

7-8: M7

9: Roll again.

Roll again if directed to enter the hex left to enter N7. Only the first German vehicle/soldier to enter and leave N7 rolls. The rest automatically follows the leader. Go to Condition 2.

101. [s0] A German convoy approaches! The convoy contains a motorcycle with sidecar, a staff car and two trucks; entering in that order. See 133 to determine where the convoy enters. Movement is one hex per turn until the American decides to commence Rounds. Americans may not move/fire/prepare weapons while in Operations. Convoy must keep closed up with no gaps and move at the speed of the slowest active vehicle (truck, staff car and motorcycle in this order). When in Rounds, drivers of active vehicles get one turn unless all drivers have two turns. Two vehicles (including disabled/immobilized vehicles) may occupy the same hex. No vehicle may pass another active vehicle, but may be in the same hex with it. To pass a hex with two disabled/immobilized vehicles or a hex with a crater costs 3 MPs and an immediate Accident Check must be made. To pass a burning vehicle, make an Accident Check. When all four vehicles are on the map, see 120. When the American player chooses to commence Rounds, see 140. Make note of these two paragraphs on your squad record. Self-preservation is not in effect for Germans in active vehicles.

Victory points are gained for activation/capture of Germans. Germans that exit the map cause a loss of double their activation VPs (if a German is worth 2 VPs for activation and exits, you lose 4 VPs). You need 16 VPs for victory.

102. Conduct PC Check:

- If successful, see 131.

- If fails, no effect.

103. [s9] A detonator wired to explosives on bridge G14 is found! An American in this hex may blow the bridge by spending one action. When the bridge is blown, place wrecked bridge marker and see 121. Make note of this paragraph on your squad record.

104. One soldier determined at random has his gun jam. Roll one die: on an odd result, an American is affected; on an even result, a German is affected. If the soldier whose gun jammed is standing, crouching or in a vehicle, he may make an immediate attempt to unjam at no cost.

105. Roll one die:

0-3: Enter T4

4-9: Enter T5

106. Conduct PC Check:

- If successful, see 143

- If fails, no effect

107. If on the first level, no effect.

If on the second level, see 152.

110. One German vehicle determined at random blows a tire, and can move only at slow speed for the rest of the mission. If the same vehicle blows a second tire, it is immobilized and the occupants must abandon it to proceed on foot. No effect on the armored car.

111. [s7] Go to Condition 4. Roll one die; odd: W11, even: E3. Activate German 16 in the hex indicated. German advantage. German receives one turn this Round. The mission ends when:

1. There are no active Germans on the map. No VP loss for Americans incapacitated.

2. All active Americans have exited any map edge. VP loss for incapacitated Americans not exited. Germans left on map cause VP loss as if they had exited. Immobilized and abandoned vehicles count as destroyed for VP purposes.

112. A grenade explodes accidentally! Roll one die: on an odd result an American is affected; on an even result, a German is affected. One soldier, determined at random and carrying a grenade, has the grenade explode. The affected soldier conducts a PC Check:

- If successful, he tosses the grenade into an adjacent hex where it explodes harmlessly.
- If fails, he and everyone in the hex are hit by the explosion. The soldier carrying the grenade is considered indoors regardless of his position. Occupants of vehicles are considered prone indoors. No other occupants of the hex may conduct a PC check for this explosion. If it occurs in a vehicle, the vehicle is disabled. This may occur only once per mission. Ignore further references to this paragraph.

120. If in Rounds, no effect.

If in Operations, each American conducts a PC Check. Move the IN markers of those who pass to the Complete space. Roll one die and place those IN markers in the appropriate location on the AR track (ignore advantage/disadvantage). Americans may now move/prepare weapons/give turns (but not fire) as if in Rounds. Panicked soldiers may do nothing but fall prone. When all the Americans have finished their turn(s), place all the American IN markers back in the Unaware space. This is the only exception to the fifth sentence of the first paragraph of 101 and the only time Americans may do anything while in Operations.

121. Any vehicle in the hex is destroyed. All occupants lose any turns remaining in the Round and roll for damage on the Pistol row of the Damage Table. Soldiers not in vehicles lose any remaining turns and roll on the Semi-automatic rifle row of the Damage Table.

122. If German N active and in vehicle, see 145. Otherwise, no effect.

123. The German radio in the staff car breaks down! Ignore further references to 122 and 123. Make a note of these two paragraphs on your squad record.

124. Go to Condition 3.

125. Roll one die:

- Odd, see 103.

- Even, see 132.

126. Roll one die:

Odd, see 167.

Even, see 137.

127. [s6] If in Operations, no effect. Otherwise, a soldier discovers a case of wine and stops to confiscate it. If there is no commander in that hex, all men lose the rest of their turn(s) for this Round. Man with the highest PC conducts a PC Check.

- If successful, all men in the hex fall prone.
- If fails, all men in the hex must remain in their current stance.

128. If any German vehicles from the convoy are burning, one chosen at random explodes. All soldiers currently in the hex roll on Satchel Charge, Inside row of the Damage Table. Remove disabled vehicle and burning markers. Place crater marker in the hex. This can occur once per mission. Ignore further references to this paragraph, even if no convoy vehicles currently burning. Occupants of vehicles are considered other than prone for resolving this explosion.

130. One German weapon chosen at random runs out of ammo.

131. [s1] Soldier finds German MMG with one clip of ammo in this hex. MMG is unprepared.

132. [s9] A detonator wired to explosives on bridge G13 is found here! An American in this hex may blow up the bridge by spending one action. When the bridge is blown, place wrecked bridge marker and see 121. Note this paragraph on your squad record.

133. Roll one die to determine entry hex:

0-1: Y16

2-3: A5

4-5: A17

6-7: Y8

8: A16

9: Y5

Activate German 11 in the hex indicated. Activate Germans 12, 13 and 14 in order as the preceding German advances one hex. German IN markers occupy Complete space until the American chooses to commence Rounds by reading 140. If all German vehicles are destroyed or immobilized and all occupants killed or incapacitated before any reach hex N7, go to Condition 3. Do not conduct Random Event Checks until in Rounds.

134. [s4] A German armored car patrolling the railroad tracks enters! It is mounted on the rails and follows the tracks when directed to move. (There are no movement references on the condition cards for the armored car.) If bridge G13 is blown or burning when the armored car gets there, it will reverse its direction of travel to its entry hex where it will exit. Roll one die: on an odd result, the armored car enters Y5 and attempts to exit A16; on an even result, the armored car enters A16 and attempts to exit Y5. Activate German 15 in the hex determined above. *Commence Rounds.* German Advantage. German 15 gets one turn per Round until fired upon.

135. You find fame and quicksand. Everyone will know who you are, but you must remain here until V-E Day.

136. If bridge G13 is intact, enter H12. Otherwise, enter I12.

137. If your radio is manned, you inform division of the approaching convoy and gain 2 VPs. Division orders you to stop or slow down the convoy. If your radio is not manned, lose 2 VPs. *Commence Rounds.* Roll for initiative.

138. If German 16, 17, 18, or 19 is moving, enter K12. Otherwise, enter I13.

140. Roll one die. Odd, see 150. Even, see 160.

141. One wounded German determined at random becomes incapacitated due to blood loss. This can occur only once per mission; ignore further references to this paragraph once the first German becomes incapacitated.

142. • If s4 has not occurred, see 134.
• If s5 has not occurred, see 153.
• If s7 has not occurred, see 111.

143. [s5] Forward elements of another company appears! They will assist you. Activate US 08 and US 09 prone in the hex that caused the PC Check. If soldier that took the PC Check was the runner activated by 167, he is told that headquarters is aware of the convoy and he is to return to his squad. Gain 2 VPs.

145. Mortar fire called in from the staff car! German N conducts PC Check:
• If fails, no contact was made with mortar squad.
• If succeeds and s3 has occurred, see 152. If succeeds and s3 has not occurred, place spotting round or move round already on the board as in mission 10. German N must attempt to hit the hex with the most visible Americans in it. If all possible target hexes have the same number of Americans in them, choose one at random. Placement of round may not be closer than 3 hexes to an active German. If all visible Americans are within 3 hexes of an active German, place the round so that it may scatter into the Americans, but not into an active German. When mortar strike location is resolved, roll on Satchel Charge,

Outside row of Damage Table for each American in the hex. Building hexes become rubble, whether occupied or not; place rubble marker. Any other hex becomes a crater; place crater marker. Lose 1 VP for each time German N successfully contacts the mortar after the first time.

146. If German 16, 17, 18, or 19 is moving, enter H7. Otherwise, enter G6.

150. All Americans conduct PC Check. Those that pass may fire at convoy, prepare weapons, or give turns (but not move). *Commence Rounds.* All Americans automatically aware, and those that do not panic receive two turns this Round. See 126.

151. One American who is wounded (the one with the lowest IN) becomes incapacitated due to blood loss. This can occur only once per mission. Ignore further references to this paragraph once the first American becomes incapacitated.

152. [s3] You find a German radio in this hex! If German N attempts to call in mortar fire, an American in this hex may try to jam the transmission. Conduct PC Check:

• If fails, no effect. Return to 145.
• If successful, German N's transmission is jammed and there is no mortar fire this Round. Gain 1 VP each time transmission is jammed.

153. [s5] Reinforcements appear. Use cards US 08 and US 09. Roll one die:

0-2: A1 to Y1
3-4: A1 to A19
5-7: A19 to Y19
8-9: Y1 to Y19

Reinforcements may enter standing and aware anywhere on the row/column determined above.

154. [s8] Activate Germans 17, 18, and 19 in the hex where the half-track is disabled/immobilized. Germans are crouching. If there have been four or more body penetrations on the half-track or the half-track was disabled by a medium or heavy body penetration, you get 4 VPs and Germans 17, 18, and 19 are not activated.

If there have been three or less light body penetrations, for each occurrence, pick one of these three Germans at random and roll on the Pistol row of the Damage Table. Even if a German is killed or incapacitated, he is to be included in later resolutions. After the light body penetration results are resolved, roll one die and place the IN markers of the survivors on the AR track according to the result.

155. Make a note of light body penetrations to the half-track on your squad record. There will be further instructions concerning this later in the mission.

156. If German 16, 17, 18 or 19 are moving, enter U4. Otherwise, enter U5.

160. All Americans are aware and those that

do not panic receive two turns this Round. See 126.

161. Roll one die:

• Odd, enter L8
• Even, enter M9

162. • If bridge in G13 is intact, enter G13.
• Otherwise, enter H13.

163. • If bridge in G14 is intact, enter G14
• If bridge in G13 is intact, enter H12.
• If neither bridge is intact, see 197.

164. • If German 16, 17, 18, or 19 is moving, enter T4.
• Otherwise, enter U6.

165. • If German 16, 17, 18, or 19 is moving, enter H6.
• Otherwise, enter F5.

166. • If German 16, 17, 18 or 19 is moving, enter J12.
• Otherwise, enter H12.

167. • If your radio is manned, it is not working. You decide to send a runner to inform division of the convoy, and the rest of the squad will try to stop it. If the man you send successfully exits the map edge opposite where the convoy entered, you gain 2 VPs. The runner must start on his next turn. He may move or move/fire, but he must move every turn he is able to.

• If your radio is not manned, lose 2 VPs. *Commence Rounds.* Roll for initiative.

168. • If German 16, 17, 18 or 19 is moving, enter S12.
• Otherwise, enter R13.

169. German exits. Go to Condition 3.

170. • If driver's turn and on motorcycle, spend 1 MP to get off motorcycle and then conduct 864.

• If driver's turn and not on motorcycle, conduct 865.

• If gunner's turn and in sidecar, spend 1 MP to get out of sidecar. Roll one die:

0-3: see 179.

4-9: see 864. Leave LMG in sidecar.

• If gunner's turn and not in sidecar, conduct 866.

178. • If only one target in sight, stand and conduct one snap fire at that target. Then move as quickly as possible, spending up to ½ the soldier's MPA, rounded down. Fall prone if free stance change available.

• If no target in sight, move as quickly as possible. Fall prone if free stance change available.

• If more than one target in sight, crouch and conduct snap fire at as many targets as possible, beginning with the closest and then the easiest. Fall prone if free stance change available.

179. Spend the rest of the turn removing LMG from sidecar, then fall prone.

190. • If driver's turn and no shots fired, drive slowly.

• If driver's turn and shots have been fired, drive fast.

• If gunner's turn and no shots fired, do nothing.

• If gunner's turn and shots have been fired, conduct best fire with LMG at closest target. (Note: do not exceed speed of slowest convoy vehicle still active.)

191. • If no shots fired, driver drives slow. Other vehicle occupants do nothing.

• If shots fired, driver drives fast. Other vehicle occupants conduct best fire at closest target.

(Note: do not exceed speed of slowest convoy vehicle still active.)

192. Drive slow. Conduct aimed fire with LMG at closest target.

193. Drive fast. If three in crew, conduct snap fire with LMG at easiest target.

194. Conduct two snap fires with LMG, first at closest target and then at easiest.

195. • If current German Action Number is odd:

On driver's turn, drive slow.

On assistant's turn, conduct best fire at easiest target.

• If current German Action Number is even:

On driver's turn, drive fast.

On assistant's turn, conduct best fire at closest target.

196. • Drive slow.

• If armored car is immobilized, conduct snap fire at closest target. If there are two or three in crew, conduct two snap fires. If only one in crew, conduct one snap fire.

197. If both bridges are wrecked, crossing may be made over the wreckage in G14. To enter or leave the wrecked bridge in G14 costs a vehicle all its Movement Points and an immediate Accident Check must be made. If the Accident Check results in disabled or crash, the vehicle slides off the wreckage into G15 and sinks. Remove the vehicle counter from the map; the vehicle is considered destroyed for VP purposes. For each occupant of the vehicle that slid off, roll one die:

0-1: Occupant panics and drowns.

2-3: Place occupant in H13, prone, wounded.

4-9: Place occupant in H13, prone. He loses any turns remaining in the Round.

Soldiers on foot may cross at the wrecked bridge in G14 at the cost of 2 MPs to enter or leave the hex. They must also roll one die when entering or leaving the hex:

0-1: Man slips off the wreckage and drowns.

2-9: No effect.

800. Lie prone.

801. Crouch, then conduct best fire at easiest target. Fall prone after fire if free stance change available.

802. Crouch, then conduct best fire at closest

target. Fall prone after fire if free stance change available.

809. Move as quickly as possible; fall prone after movement, spending a MP to do so, if necessary.

812. 1. If active US soldier in hex, assault to kill.

2. If adjacent to active US soldier through traversible hexside and a grenade is available, crouch and throw grenade. Exception: if another active German is in the hex with the US soldier, charge assault to kill.

3. If an active target is in sight and no German is in target hex, crouch and conduct best fire.

4. Move and snap fire at any target that becomes visible during movement.

815. Crouch, then fire machine gun or assist in firing machine gun. Conduct best fire at any target within three hexes. Otherwise, conduct aimed fire at easiest target. Fall prone after fire if free stance change available. If MG out of ammo, fire second weapon.

819. • If grenade is available and target in range, throw grenade at closest target. Fall prone after throw if free stance change available.

• If no grenade available or target in range, run into an open hex or crawl into any other type hex.

822. • If an active German in the same or adjacent hex, crouch and give a turn to the German with the fewest turns in the same or adjacent hex. If two or more eligible Germans have the same number of turns, give a turn to the one with the highest Weapon Skill. If all eligible Germans have two turns, conduct 801.

• If no active Germans in the same or adjacent hexes, run into an open hex or crawl into any other type of hex.

832. • If an active German in the same or adjacent hex, crouch and give a turn to the German with the fewest turns. If two or more eligible Germans have the same number of turns, give the turn to the one with the highest Weapon Skill. If all available Germans have two turns, see 801.

• If no other active Germans in the same or adjacent hex, conduct 801.

833. 1. If active US soldier in hex, assault to kill.

2. If adjacent to active US soldier through traversible hexside and a grenade is available, crouch and throw grenade. Exception: if active German in US hex, charge assault to kill.

3. If active target in sight, crouch and conduct best fire.

4. Lie prone.

839. • If active US soldier in hex, assault to kill.

• If no active target in hex, crouch and conduct best fire at closest target.

862. • If no active target in sight, move as quickly as possible. Fall prone if an active tar-

get is in sight and free stance change available.

• If active target is in sight and soldier occupies an open hex, move as quickly as possible. Fall prone after movement, spending a MP if need be.

• If active target in sight and soldier occupies a non-open hex, crouch and conduct best fire at easiest target.

864. • If no active target in sight, move as quickly as possible. Fall prone if an active target in sight and free stance change available.

• If active target in sight, stand and conduct one snap fire at closest target. Then, move as quickly as possible, spending up to 1/2 soldier's MPA, rounded down. Fall prone if free stance change available.

865. • If no active target in sight, move as quickly as possible. Fall prone if an active target is in sight and free stance change available.

• If one or two active targets in sight, crouch and conduct best fire at closest target.

• If three or more targets in sight, fall prone.

866. • If no active target in sight, move as quickly as possible. Fall prone if an active target is in sight and free stance change available.

• If one or two active targets in sight, move as quickly as possible. Fall prone in first non-open hex entered, spending a MP if need be. If no non-open hex entered, fall prone in the last hex entered, spending a MP if need be.

• If three or more active targets in sight, crouch and conduct as many snap fires as possible, first at the closest target and then the easiest.

868. Move as fast as possible. Fall prone after movement if free stance change available and an active US soldier is in sight.

869. • If grenade available and active US soldier within three hexes, stand up and thrown grenade. Fall prone if free stance change available.

• If grenade not available or target at four or more hex range, conduct 801.

971. • If no active targets in hex, lie prone.

• If one or two active targets in hex, assault to kill the one with the lower Weapon Skill.

• If three or more active targets in hex, surrender.

972. • If bridge G13 is intact, enter G13.

• Otherwise, enter F14.

973. • If bridge G14 intact, enter G14.

• If bridge G13 intact, enter F13.

• If both bridges destroyed, see 197.

continued from page 2

Vietnam Comments

Congratulation to Tony Curtis for his fine *Victory Insider* article on VG's *Vietnam* game. I was so impressed that I was finally persuaded to subscribe to *The General* and *Victory Insider*.

Although I cannot judge the rapid build-up strategy from first-hand experience yet, it certainly seems to offer the US player his best chance for success. However, I think a few adjustments to the first season's deployment might improve the US player's position even more.

Suggested Summer 1965 US Deployment

Units	Commitment
Withdraw 1 Navel Point	-4
Rest of 3rd Marine Div	4
101st Airmobile Div	10
1st Air Cav Div	9
1st Marine Div	9
4 155mm Artillery Bn	4
6 Air Points	2
8 Airmobile Points	4
21 Replacements	7
35 ARVN Supplies	5
	<hr/> 50

Compared with Mr. Curtis' deployment, this gives up a naval point, 27 air points, and 2 to 6 SVN morale points, but adds a US division

(with 32 artillery points), 7 points of independent artillery and 35 ARVN supplies. These supplies are used for replacements, battalion upgrades, and a few division HQs. The US player can place these HQs under effective Corps commanders, converting some otherwise useless ARVN divisions into effective units.

In addition, I'd suggest that the US player eventually deploy up to nine US divisions. Since they bring their own firepower with them, they can be taken in place of air points. If these extra units are later under-employed, as Mr. Curtis warns, they can always be withdrawn (reclaiming, incidentally, several "free" commitment points for their HQs).

Finally, a word about the "gamesmanship" Mr. Curtis criticizes. In the real world, the most successful leaders invent new "rules" for the "game" of military conflict. Although wargamers are much more restricted, they can simulate this real-world innovation to some extent by creative exploitation of their game's rules. If, for instance, the US player deploys only one brigade with a division HQ, it just means that Westmoreland has decided the division's artillery is more useful than its infantry, and has broken military tradition to get it. The rapid build-up strategy itself may be another example of gamesmanship: I can't help wondering if the US actually had the logistical resources to deploy the real-life equivalent of 50 commitment points in Vietnam during the summer of '65. My point is that without some freedom from historical constraints, gamers can only repeat history, not change it.

Gary Hladik
Saratoga, CA

continued from page 3

matching requirements). Instead, they are simply delayed until the matching requirement is met.

157: Delete the note accompanying this rule, and add the following: "An Offensive Support marker cannot be transferred directly from one HQ to another in the same Game-Turn. Instead, the marker must first be removed from an HQ during a friendly Offensive Support Phase and placed on the Game-Turn Track. Then, during the next friendly Offensive Support Phase, the marker can be returned to play atop any eligible HQ."

171: Delete this rule and substitute the following: "Exploitation: A hard unit that has advanced after combat without crossing a Major River hexside can use exploitation to advance one additional hex into any adjacent hex not occupied by an enemy unit. A unit cannot exploit into or out of any of the following hex types: major or key city, mountain, rough, marsh, or a hex containing a Chemical Warfare or Interdiction marker. Additionally, a unit cannot use exploitation to exit an enemy Zone of Control hex, though it can exploit into any type of enemy Zone hex."

172: Change the words "of a given type" to "of each type."

186: Change "1 to 4" to "1 to 3."

187: (Addition) The tactical nuclear die roll mechanic is intended to reflect the possibility of provoking a massive strategic retaliatory strike when a player initiates Tactical Nuclear Warfare. In this case, the initiating player loses decisively because he has brought down Armageddon.

206: To control a city for purposes of this rule, the city must be in WP friendly airspace.

211: Change "during Game-Turns 2 and 3" to "during Game-Turns 2, 3 and 4."

222: Change "Zone of Control" to "Zone of Delay."

235: Change the first sentence to read as follows: "When a NATO unit other than an airborne, airmobile, or marine unit enters any city hex in East Germany, and occupies the hex during a Victory Points Record Phase, the Warsaw Pact player must enter the 6 East German Territorial Reserve reinforcements during his next Activation/Reinforcement Phase, and the NATO player immediately receives 3 Victory Points."

236: Change the first sentence to read as follows: "When a NATO unit other than an airborne, airmobile, or marine unit enters any city in Czechoslovakia, and occupies the hex during a Victory Points Record Phase, the Warsaw Pact player must enter the 3 Czech Territorial Reserve reinforcements during his next Activation/Reinforcement Phase, and the NATO player immediately receives 3 Victory Points."

Terrain Effects Chart:

Major City: The note is supposed to read "For movement and combat purposes, Major and Key cities are treated identically."

Major River Hexside: Change the Attack Die Roll Penalty from "-2" to "0" and delete the first sentence of the note. Change the second sentence to read "If some units attack across Major, and others across Minor, River hexsides, but all units are attacking across some form of River hexside, then the combat penalties of both types of River hexside apply simultaneously."

Iron Curtain Hexside: The Movement Point Cost should be changed from "+1" to "NOTE." The note should be deleted and replaced with the following note: "See NATO Border Troop rule (222) for Game-Turn 2 effects."

Attack Die Roll Penalty Explanation Section: Add the following sentence: "The Attack Die Roll Penalty for attacking across a Minor River hexside never applies to Airstrike missions or Nuclear Strikes."

Danish Ferry: Change the words "A maximum total of 2 steps of NATO units" to "A maximum total of 2 steps of NATO units per Game-Turn."

Combat Modifier Applications:

Attack Strength: Change the last sentence in this section to read "Once all these modifiers, all of which are cumulative, are taken into account for each attacking unit, add all modified strengths, fractions included, to determine the total Attack Strength. Round any remaining fractions down."

Attack Die Roll Penalty: Change the last sentence in this section to read "If the attacking units are all attacking across Minor River hexsides, or a combination of Minor and Major River hexsides, subtract one more from the die roll, as indicated on the Terrain Effects Chart for Minor River hexsides."

Zone Effects Summary:

Effects of an Enemy Zone of Delay Hex: Change the third sentence of this section to read "A friendly unit cannot enter or leave an enemy Zone of Delay hex by rail transport (115), Air Ferry (120), or Sea Ferry (127)."

Effects of an Enemy Zone of Control Hex: Insert the following sentence immediately after the first sentence in this section: "A friendly unit moving by tactical road movement must always stop in the first enemy Zone of Control hex that it enters and may not be moved any further in that Movement Phase."

Change the fourth sentence in this section to read "A friendly unit cannot enter or leave an enemy Zone of Control by rail transport (115), Air Ferry (120), or Sea Ferry (127)."

Map:

Several minor cities in forest hexes are white rather than the intended red. They are minor cities for all purposes.

With Victory Games, Inc.

STRATEGY GAMES & SIMULATIONS

You Get What You PLAY For. . .

✓ **Quality** ✓ **Excitement** ✓ **Challenge**

Victory Games, Inc. knows as well as you do that the very best simulations and strategy games are a product of design experience bringing fresh, new ideas to the gaming public. Now the most innovative and respected company in the field is prepared to prove that point again!

New Module for the Award-Winning Ambush!



PURPLE HEART
\$22.00

Six new missions for the phenomenal *Ambush!* solitaire game system. Includes new maps and counters.

PAX BRITANNICA
\$24.00

Multi-player game of colonization and empire building from 1880 to the outbreak of the Great War.



A Dynamic Multi-Player Game of the Age of Empire



A Detailed Simulation of Modern War at Sea

Exciting Multi-Player Game of Modern Politics

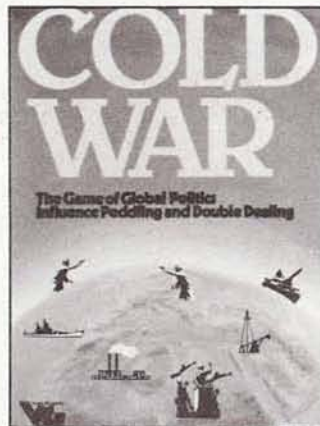

COLD WAR
\$24.00

Multi-player game of intrigue and global influence-peddling in the contemporary world in an easy-to-learn format.

SIXTH FLEET
\$30.00

More than 600 playing pieces and two maps in a panoramic simulation of naval combat in the Mediterranean.

EXCLUSIVE FOREIGN DISTRIBUTORS

UK: AVALON HILL GAMES, 650 High Road, North Finchley, London N12 0NL, England. Telephone 01-445-3044. **Australia:** JEDKO GAMES, 134 Cochranes Road, Moorabbin, Victoria 3189, Australia. Telephone (03) 555 1022. **Japan:** POST HOBBY, 26-5 5-Chome, Sendagaya, Shibuya-Ku, Tokyo, Japan. Telephone (379) 4081. **Sweden:** TARGET/TRADITION, Storgatan 29, S-114 55 Stockholm. Telephone (08) 61 93 01.



43 West 33rd Street
New York, NY 10001



GULF STRIKE IS A SMASH!

"Gulf Strike is an excellent, ambitious, demanding simulation and is certainly a feather in Microcomputer Games' cap. The exclusive joystick input device is a pleasure and the game's sound effects guide the player along as well. These features make the game immediately playable, with only a minimal scanning of the rules. The rules are well written and complete (with designer's notes), with interesting military data which explain in detail the natures of the armies and equipment simulated. The game explores a touchy subject and offers plausible insights into conflict in the region."

Ian Chadwick, Strategy & Tactics Magazine

"Game of the Month"

Jerry Pournelle, Byte

"Never slow and always completely involving. The result is a major leap forward for the genre, and the best computer wargame to date." Rating: **** (Excellent)

Family Computing "84's Finest"

Year's Best Software: "Gulf Strike combines land, sea, and air combat in an interesting 'what-if' game."

Games Magazine

"One of Avalon Hill's best computer wargames to date."

Computer Gaming World

Gulf Strike. Despite its war with Iraq, Iran has been criticizing the Soviet presence in Afghanistan and openly supplying arms to the Moslem rebels. Invoking the 1921 Treaty of Friendship with Iran, the Soviet Union responds by rolling across the Iranian border. The course of future history is now up to you.

Gulf Strike examines every aspect of this complex region. With your joystick, maneuver air units, navies and armies from a dozen countries over a full-color scrolling map of Iran, Iraq, and the

Persian Gulf. Its ease of play allows you to concentrate on commanding your forces, not wrestling the computer. See why reviewers are calling **Gulf Strike** the strategy game of the year for your Atari computer.

Gulf Strike is now available for the Atari Home Computer System, for one disk drive and joystick. \$30.00



microcomputer games[®]

A Division of The Avalon Hill Game Company
4517 Harford Road, Baltimore, MD 21214

Atari is a trademark of the Atari Corporation.

Call Toll-Free 1-800-638-9292 for ordering information and the location of a store near you. Ask for Operator 1.